

NUTPLATE MEETS THE STRENGTH REQUIREMENTS OF NASM25027.

MATERIAL AND FINISH DATA

CODE	NUT MATERIAL	SPEC.	FINISH	SPEC.	DRI-FILM LUBE
CR	A-286 CRES	AMS 5525, 5726, 5731, 5732, 5737	PASSIVATE	AMS-QQ-P-35	MIL-PRF-46010
CRC			CAD PLATE	AMS-QQ-P-416 TY II, CL 2	

CODE	WASHER MATERIAL	SPEC.	FINISH	SPEC.
CR	A-286 CRES	AMS 5525, 5726, 5731, 5732, 5737	PASSIVATE	AMS-QQ-P-35
ACR	2024 OR 6061 ALUMINUM	AMS-QQ-A-200 OR AMS-QQ-A-225	ANODIZE	MIL-A-8625

INSTALLATION HOLE SIZE

THD SIZE CODE	U MAX
04	.142
06	.168
08	.194

OPTIONAL PRIMER

CODE	BASEPLATE PRIMER	SPEC.
P	EPOXY PRIMER	MIL-PRF-85582

OPTIONAL TOPCOAT

CODE	SPEC.
F	AMS-C-27725, TYPE 2 CLASS B YELLOW

THREAD AND DIMENSION DATA (ALL DIMENSIONS BEFORE PAINT)

CODE	THREAD SIZE T	D MIN	COLOR CODE
04	.112-40 UNJC-3B	.142	YELLOW
06	.138-32 UNJC-3B	.168	BLUE
08	.164-32 UNJC-3B	.194	RED

ADHESIVE BOND

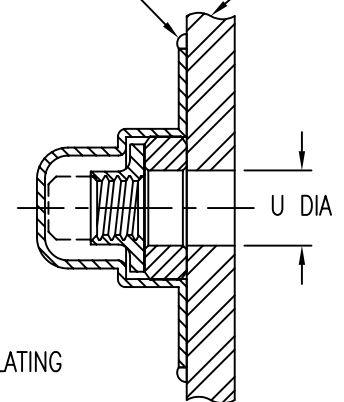

EXAMPLE PART NUMBER

CB9121 CR 08 CR P F

OPTIONAL TOPCOAT ON DOME  
OPTIONAL PRIMER ON BASEPLATE  
NUT MATERIAL - A-286 CRES, NO PLATING  
THREAD SIZE - .164-32 UNJC-3B  
DOME AND WASHER MATERIAL - A-286 CRES  
BASIC PART NUMBER

UNLESS OTHERWISE SPECIFIED, ALL DIMENSIONS ARE IN INCHES AND TOLERANCES ARE AS SHOWN BELOW. DIMENSIONAL TOLERANCES AND SYMBOLS PER ANSI Y14.5M-1982.

PROPRIETARY PARTS SHOWN IN THIS DRAWING ARE THE SUBJECT OF ISSUED UNITED STATES AND FOREIGN PATENTS AND PATENTS PENDING. UNAUTHORIZED REPRODUCTION AND/OR DISTRIBUTION OF THIS DRAWING IS SPECIFICALLY PROHIBITED.

**GLICK BOND**

CARSON CITY  
NEVADA 89706

CAD CB9121-1		APPROVALS	DATE	TITLE			
ANGLES	±1°	DRAWN	PMM	NUTPLATE, MINIATURE, FLOATING, SEALED, TWO LUG			
.XX	±.03	CHECKED	30DEC04	SIZE	CAGE CODE	DWG. NO.	REV.
.XXX	±.010	RELEASED	2JAN05	A	66530	CB9121	2
.XXXX	±.001	REVISED	30DEC04	SCALE	2/1	30DEC04	SHEET 1 OF 2

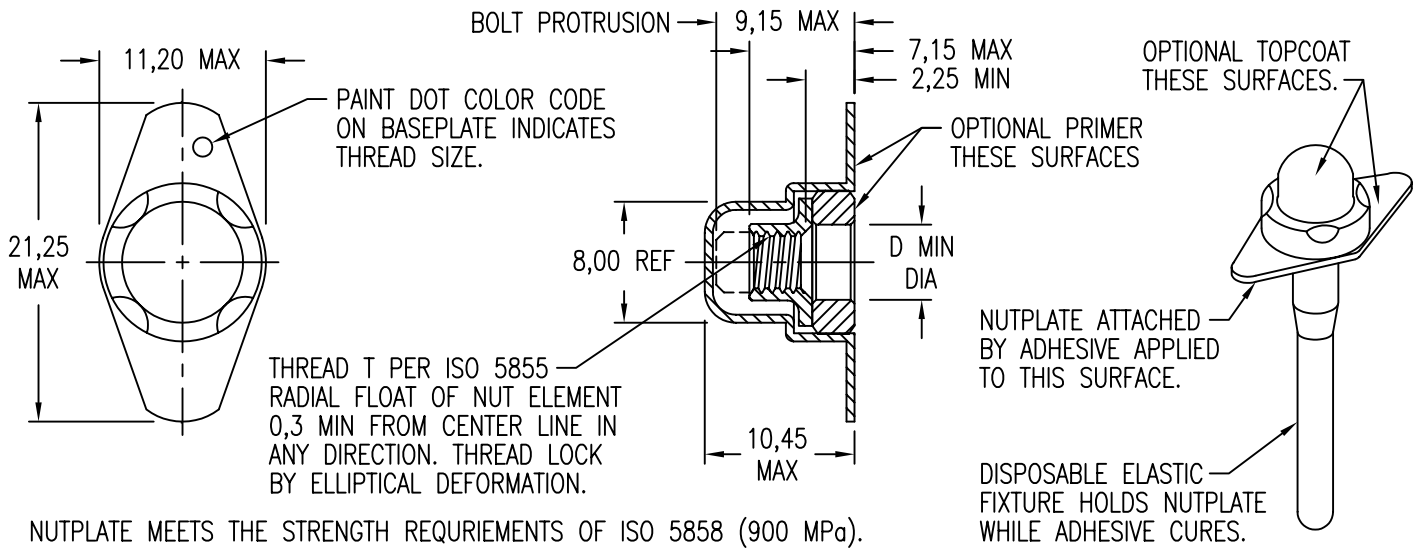

MATERIAL AND FINISH DATA

CODE	NUT MATERIAL	SPEC.	FINISH	SPEC.	DRI-FILM LUBE
CR	A-286 CRES	AMS 5525, 5726, 5731, 5732, 5737	PASSIVATE	AMS-QQ-P-35	MIL-PRF-46010
CRC			CAD PLATE	AMS-QQ-P-416 TY II, CL 2	

CODE	DOME MATERIAL	SPEC.	PASSIVATE
CR	A-286 CRES	AMS 5525, 5726, 5731, 5732, 5737	AMS-QQ-P-35
ACR			

CODE	WASHER MATERIAL	SPEC.	FINISH	SPEC.
CR	A-286 CRES	AMS 5525, 5726, 5731, 5732, 5737	PASSIVATE	AMS-QQ-P-35
ACR	2024 OR 6061 ALUMINUM	AMS-QQ-A-200 OR AMS-QQ-A-225	ANODIZE	MIL-A-8625

INSTALLATION HOLE SIZE

THD SIZE CODE	U MAX
3M	3,6
4M	4,6

OPTIONAL PRIMER

CODE	BASEPLATE PRIMER	SPEC.
P	EPOXY PRIMER	MIL-PRF-85582

OPTIONAL TOPCOAT

CODE	SPEC.
F	AMS-C-27725, TYPE 2 CLASS B YELLOW

THREAD AND DIMENSION DATA (ALL DIMENSIONS BEFORE PAINT)

CODE	THREAD SIZE T	D MIN	COLOR CODE
3M	MJ3 X 0,5 4H6H	3,6	GOLD
4M	MJ4 X 0,7 4H6H	4,6	GREEN

ADHESIVE BOND

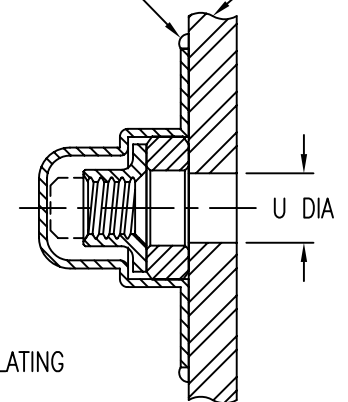

EXAMPLE PART NUMBER

CB9121 CR 4M CR P F

OPTIONAL TOPCOAT ON DOME  
OPTIONAL PRIMER ON BASEPLATE  
NUT MATERIAL - A-286 CRES, NO PLATING  
THREAD SIZE - MJ4 X 0,7 4H6H  
DOME AND WASHER MATERIAL - A-286 CRES  
BASIC PART NUMBER

UNLESS OTHERWISE SPECIFIED, ALL DIMENSIONS ARE IN MILLIMETERS AND TOLERANCES ARE AS SHOWN BELOW. DIMENSIONAL TOLERANCES AND SYMBOLS PER ANSI Y14.5M-1982.

PROPRIETARY PARTS SHOWN IN THIS DRAWING ARE THE SUBJECT OF ISSUED UNITED STATES AND FOREIGN PATENTS AND PATENTS PENDING. UNAUTHORIZED REPRODUCTION AND/OR DISTRIBUTION OF THIS DRAWING IS SPECIFICALLY PROHIBITED.

**GLICK BOND**

CARSON CITY  
NEVADA 89706

CAD CB9121-2 METRIC DIMENSIONS	
ANGLES	±1°
.X	±0,8
.XX	±0,25

APPROVALS	DATE
DRAWN PMM	30DEC04
CHECKED <i>DDC/mtm</i>	30DEC04
RELEASED <i>CGH</i>	2JAN05
REVISED PMM	30DEC04

TITLE			
NUTPLATE, MINIATURE, FLOATING, SEALED, TWO LUG			
SIZE	CAGE CODE	DWG. NO.	REV.
A	66530	CB9121 (METRIC)	2
SCALE	2/1 30DEC04		SHEET 2 OF 2