

THREAD PER AS8879.
 RADIAL FLOAT OF NUT ELEMENT
 .020 MIN FROM CENTER.
 NUT CAN ENGAGE SCREW FROM
 MAX MISALIGNED POSITION.
 THREAD LOCK BY ELLIPTICAL
 DEFORMATION. NUTPLATE MEETS
 THE STRENGTH AND REUSABILITY
 REQUIREMENTS OF NASM25027.

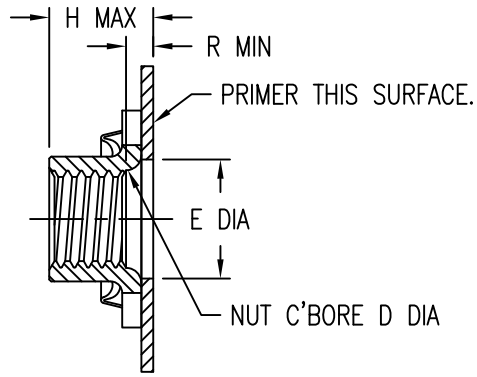

NUTPLATE ATTACHED
 BY ADHESIVE APPLIED
 TO THIS SURFACE.

DISPOSABLE ELASTIC
 FIXTURE HOLDS NUTPLATE
 WHILE ADHESIVE CURES.

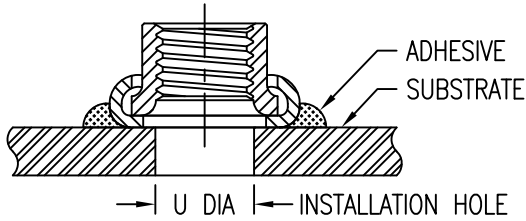

THREAD AND DIMENSION DATA (ALL DIMENSIONS BEFORE PAINT)

CODE	THREAD SIZE	A MAX	B MAX	D MIN	E MIN	H MAX	R MIN	U	WEIGHT * (LB/100)
04	.1120-40 UNJC-3B	.651	.315	-	.152	.153	-	.112-.152	.14
06	.1380-32 UNJC-3B	.682	.357	-	.178	.171	-	.138-.178	.17
08	.1640-32 UNJC-3B	.707	.367	.168	.204	.250	.062	.164-.204	.30
3	.1900-32 UNJF-3B	.739	.416	.194	.230	.250	.062	.190-.230	.36
4	.2500-28 UNJF-3B	.801	.500	.254	.290	.281	.062	.250-.290	.60
5	.3125-24 UNJF-3B	1.010	.581	.317	.352	.328	.062	.312-.352	1.14

* APPROXIMATE WEIGHT WITHOUT DISPOSABLE INSTALLATION FIXTURE.

NUT MATERIAL AND FINISH DATA

CODE	MATERIAL	SPEC.	FINISH	SPEC.	DRI-FILM LUBE
-	A-286 CRES	AMS 5525, 5726, 5731, 5732, 5734, 5737	PASSIVATE	AMS 2700	AS5272 TYPE 1
CRC	A-286 CRES	AMS 5525, 5726, 5731, 5732, 5734, 5737	CAD PLATE	AMS-QQ-P-416	AS5272 TYPE 1

BASEPLATE MATERIAL AND FINISH DATA

CODE	MATERIAL	SPEC.	PASSIVATE
CR	A-286 CRES	AMS 5525	AMS 2700

BASEPLATE PRIMER

CODE	MATERIAL SPEC.
NONE	
P	MIL-PRF-85582

PART NUMBER SUFFIXES

CODE	DESCRIPTION
NL	NON-LOCKING NUT ELEMENT
X015	NO PRIMER (NOTE: INTENDED FOR OPTICS OR SPACE APPLICATIONS)

EXAMPLE PART NUMBER

CB6014 CR 4 - 1 P

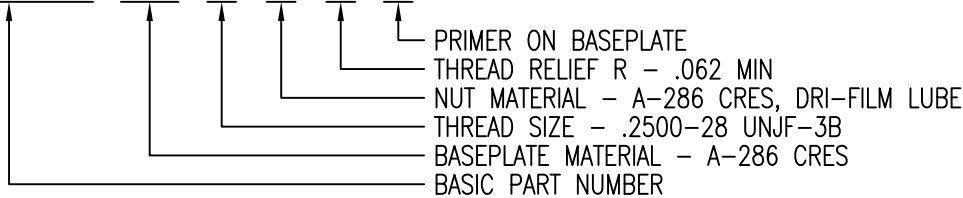

UNLESS OTHERWISE SPECIFIED, ALL DIMENSIONS ARE IN INCHES AND TOLERANCES ARE AS SHOWN BELOW. DIMENSIONAL TOLERANCES AND SYMBOLS PER ANSI Y14.5M-1982.

PROPRIETARY PARTS SHOWN IN THIS DRAWING ARE THE SUBJECT OF ISSUED UNITED STATES AND FOREIGN PATENTS AND PATENTS PENDING. UNAUTHORIZED REPRODUCTION AND/OR DISTRIBUTION OF THIS DRAWING IS SPECIFICALLY PROHIBITED.

CLICK BOND

CARSON CITY
 NEVADA 89706

CAD CB6014-1

APPROVALS DATE

TITLE

ANGLES	±1°
.XX	±.03
.XXX	±.010
.XXXX	±.001

DRAWN	DAC	27SEP10
CHECKED	DAC/mtm	27SEP10
RELEASED	ABC/mtm	27SEP10
REVISED	DAC	27SEP10

NUTPLATE, MINIATURE, FLOATING			
SIZE	CAGE CODE	DWG. NO.	REV.
A	66530	CB6014	8
SCALE	2/1	27SEP10	SHEET 1 OF 2

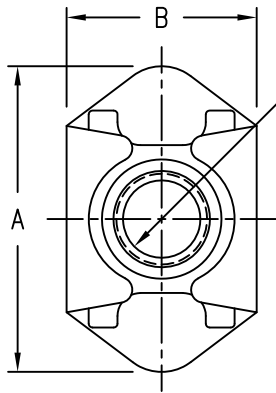

THREAD PER ISO 5855.
 RADIAL FLOAT OF NUT ELEMENT
 0,5 MIN FROM CENTER.
 NUT CAN ENGAGE SCREW FROM
 MAX MISALIGNED POSITION.
 THREAD LOCK BY ELLIPTICAL
 DEFORMATION. NUTPLATE MEETS
 THE STRENGTH AND REUSABILITY
 REQUIREMENTS OF ISO 5858
 (900 MPa).

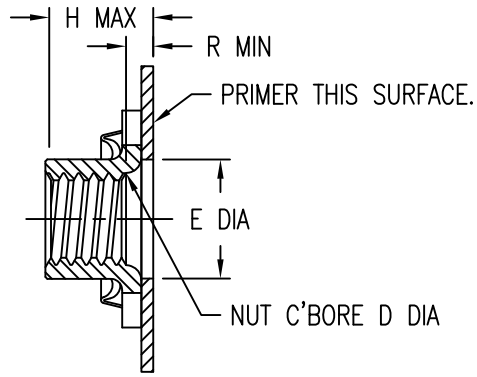

NUTPLATE ATTACHED
 BY ADHESIVE APPLIED
 TO THIS SURFACE.

DISPOSABLE ELASTIC
 FIXTURE HOLDS NUTPLATE
 WHILE ADHESIVE CURES.

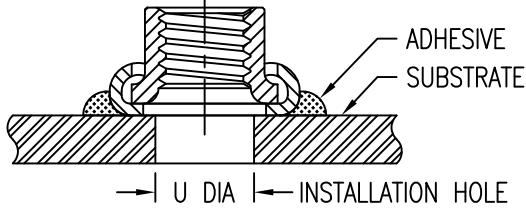

THREAD AND DIMENSION DATA (ALL DIMENSIONS BEFORE PAINT)

CODE	THREAD SIZE	A MAX	B MAX	D ±0,1	E MIN	H MAX	R MIN	U	WEIGHT * (GRAMS)
4M	MJ4 X 0,7 4H6H	18,0	9,4	4,2	5,0	5,1	1,3	4,0-5,0	1,4
5M	MJ5 X 0,8 4H6H	18,8	10,6	5,2	6,0	6,1	1,3	5,0-6,0	1,6
6M	MJ6 X 1,0 4H5H	20,4	12,7	6,2	7,0	6,8	1,3	6,0-7,0	2,8
8M	MJ8 X 1,0 4H5H	25,7	14,8	8,2	9,0	8,2	1,3	8,0-9,0	5,2

* APPROXIMATE WEIGHT WITHOUT DISPOSABLE INSTALLATION FIXTURE.

NUT MATERIAL AND FINISH DATA

CODE	MATERIAL	SPEC.	FINISH	SPEC.	DRI-FILM LUBE
NONE	A-286 CRES	AMS 5525, 5726, 5731, 5732, 5734, 5737	PASSIVATE	AMS 2700	AS5272 TYPE 1
CRC	A-286 CRES	AMS 5525, 5726, 5731, 5732, 5734, 5737	CAD PLATE	AMS-QQ-P-416	AS5272 TYPE 1

BASEPLATE MATERIAL AND FINISH DATA

CODE	MATERIAL	SPEC.	PASSIVATE
CR	A-286 CRES	AMS 5525	AMS 2700

BASEPLATE PRIMER

CODE	MATERIAL SPEC.
NONE	MIL-PRF-85582
P	

PART NUMBER SUFFIXES

CODE	DESCRIPTION
NL	NON-LOCKING NUT ELEMENT
X015	NO PRIMER (NOTE: INTENDED FOR OPTICS OR SPACE APPLICATIONS)

EXAMPLE PART NUMBER

CB6014 CR 6M 1 P

PRIMER ON BASEPLATE
 THREAD RELIEF R - 1,3 MIN
 NUT MATERIAL - A-286 CRES, DRI-FILM LUBE
 THREAD SIZE - MJ6 X 1,0 4H5H
 BASEPLATE MATERIAL - A-286 CRES
 BASIC PART NUMBER

UNLESS OTHERWISE SPECIFIED, ALL DIMENSIONS ARE IN MILLIMETERS AND TOLERANCES ARE AS SHOWN BELOW. DIMENSIONAL TOLERANCES AND SYMBOLS PER ANSI Y14.5M-1982.

PROPRIETARY PARTS SHOWN IN THIS DRAWING ARE THE SUBJECT OF ISSUED UNITED STATES AND FOREIGN PATENTS AND PATENTS PENDING. UNAUTHORIZED REPRODUCTION AND/OR DISTRIBUTION OF THIS DRAWING IS SPECIFICALLY PROHIBITED.

CLICK BOND

CARSON CITY
 NEVADA 89706

CAD CB6014-2 METRIC DIMENSIONS	
ANGLES	±1°
.X	±0,8
.XX	±0,25

APPROVALS	DATE
DRAWN <i>DAC</i>	27SEP10
CHECKED <i>DAC</i>	27SEP10
RELEASED <i>ABC</i>	27SEP10
REVISED <i>DAC</i>	27SEP10

TITLE NUTPLATE, MINIATURE, FLOATING			
SIZE A	CAGE CODE 66530	DWG. NO. CB6014 (METRIC)	REV. 8
SCALE 2/1	27SEP10	SHEET 2 OF 2	