

DISPOSABLE PRESSURE SENSITIVE ADHESIVE FIXTURE HOLDS MOUNT WHILE ADHESIVE CURES.

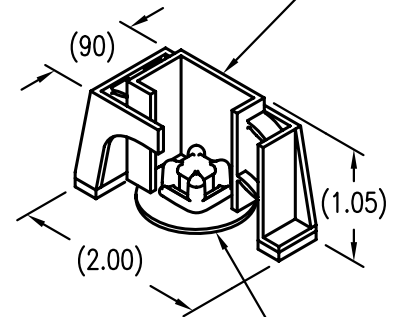

MOUNT ATTACHED BY ADHESIVE APPLIED TO THIS SURFACE.

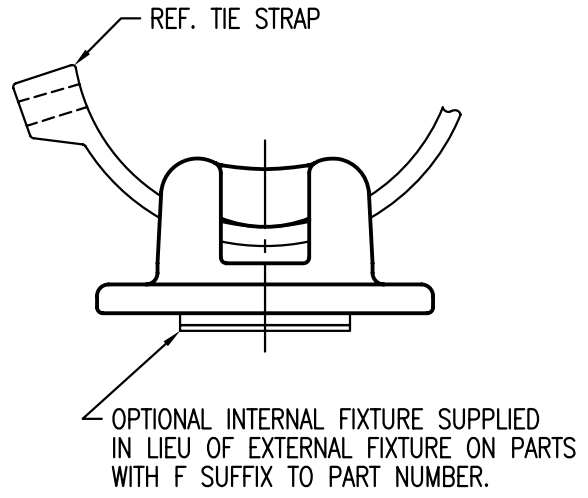
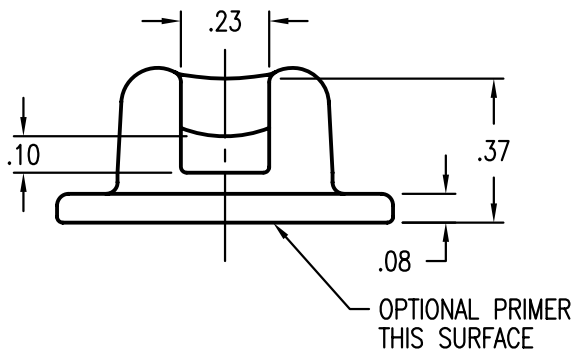

MATERIAL AND FINISH DATA

CODE	MATERIAL	FINISH
V	40% GLASS/PEI	ABRASIVE CLEAN

OPTIONAL BASEPLATE PRIMER

CODE	MATERIAL SPEC.
P	MIL-PRF-85582

EXAMPLE PART NUMBER

CB4063 V 3 P F

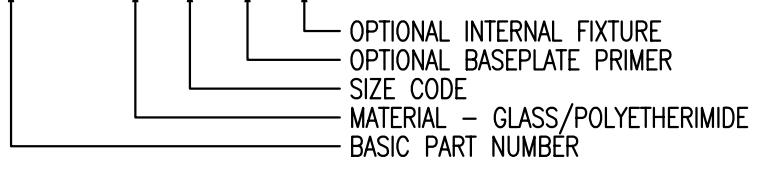

UNLESS OTHERWISE SPECIFIED, ALL DIMENSIONS ARE IN INCHES AND TOLERANCES ARE AS SHOWN BELOW. DIMENSIONAL TOLERANCES AND SYMBOLS PER ANSI Y14.5M-1982.

PROPRIETARY PARTS SHOWN IN THIS DRAWING ARE THE SUBJECT OF ISSUED UNITED STATES AND FOREIGN PATENTS AND PATENTS PENDING. UNAUTHORIZED REPRODUCTION AND/OR DISTRIBUTION OF THIS DRAWING IS SPECIFICALLY PROHIBITED.



CARSON CITY NEVADA 89706

		APPROVALS	DATE
ANGLES	±1°	DRAWN BPEREZ	7AUG07
.XX	±.03	CHECKED CGH	7AUG07
.XXX	±.010	RELEASED CGH	7AUG07
.XXXX	±.001	REVISED BPEREZ	7AUG07

TITLE			
MOUNT, CABLE TIE, TWO WAY			
SIZE	CAGE CODE	DWG. NO.	REV.
A	66530	CB4063	1
SCALE	2/1 7AUG07		SHEET 1 OF 1